

For use to 1 in. w.g. and 1500 FPM

Standard Construction and Materials

- FRAME:** 22 GA. galvanized steel, 7½" deep with reinforcing ribs.
- BLADE:** 20 GA. galvanized steel.
- SHAFT:** ½" dia. plated steel stub, mono-bolted to blade.
- BEARINGS:** Swaged steel.
- ACTUATOR:** Hand quadrant, factory mounted.
- TEMP LIMIT:** 250°F.
- FINISH:** Mill.

Notes

1. ¼" nominal deduction will be made to the opening size given.
2. Round dampers are available in 1" increments only.
3. This damper is designed for manual balancing applications.
4. The rolled ribs in the frame provide greater reinforcement, ease of installation, and a sealing joint.
5. To calculate approximate shipping weight (lbs./in.), use the following formula:
Diameter (in.) × 0.45 (lbs./in.)

Damper Sizes

Min Dia.	Max Dia.
4" O.D.	24" O.D.

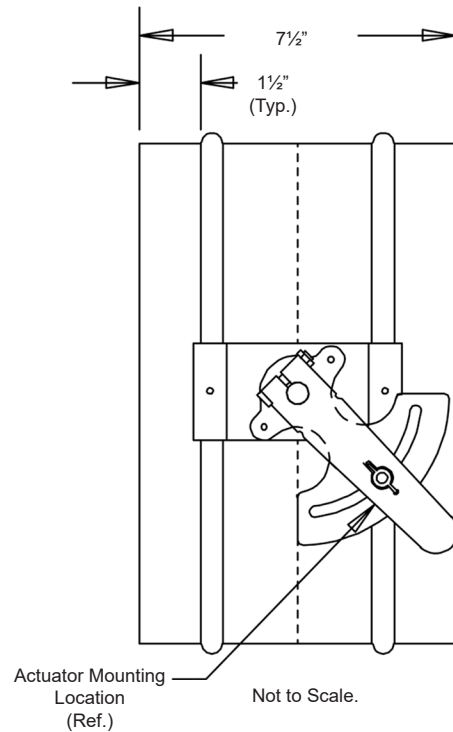
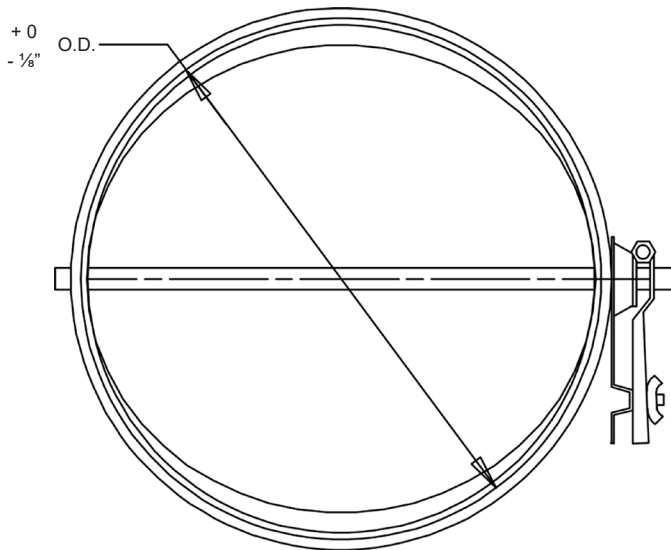

						 <p>Union Made</p>	
Item #	Qty	Damper Size O.D.	Tagging	Remarks			
Arch. / Eng.:			EDR:	ECN:	Job:		
Contractor:							
Project:			Date:	DWN:	DWG:		

In the interest of product development, Cesco Products reserves the right to make changes without notice.



450 Riverside Dr • Wyalusing PA, 18853
 Phone: 570-746-1888 • Fax: 570-746-9286
 www.cescoproducts.com

■ Performance Data

Pressure drop ratings are based on AMCA Standard 500 using test set-up figure 5.3 for a damper installed with duct upstream and downstream. Static pressures are corrected to .075 lb./cu.ft. air density.

